

Unit Dose / Reclaimable Packaging



Unit Dose / Reclaimable Packaging: Highly versatile, cost efficient and practical. Print, package and seal a wide variety of unit dose dispensing systems ranging from 24-hour dosing to 30-day regimen.

One Package For: Punch Card (Reclaimable), Unit Dose Box, 14-Day, 7-Day and Single Dose.

Blisters

We offer a variety of blisters in standard blue and amber.

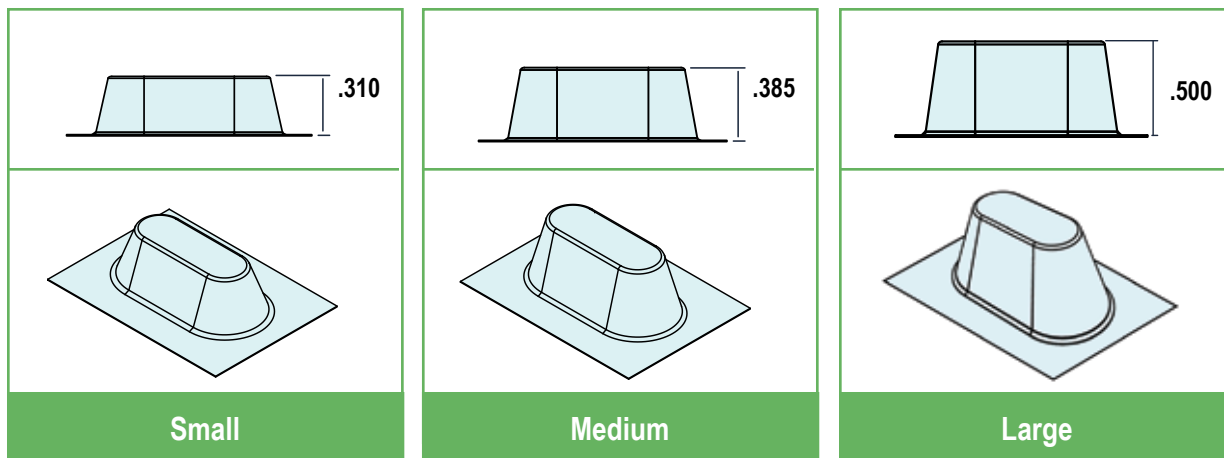

(Designed to nest together to optimize Box, Cart and Shelf space.)

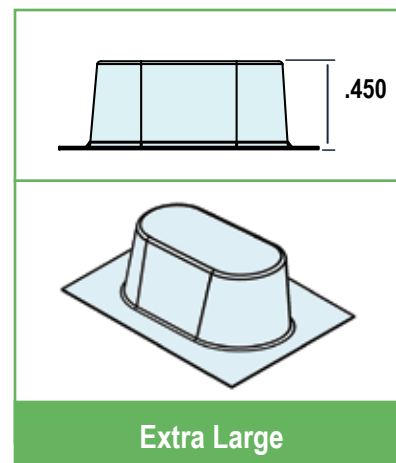

(Does not nest)

Reclaimable Packaging System



Blister Packs

Item No.	Description
201-10	Small
201-11	Medium
201-13	Large
203-16	Large Amber
201-13XL	Extra Large (Does not nest)



Refer to page 5 for sizes

Note: Standard Unit Dose Blister Packs are produced 32 per sheet (4x8). Select blister sizes are available in 14, 28, 30 and 31 dose.



Foil

Item No.	Description
680-10	Dot Matrix Foil
680-11	Thermal Transfer Foil - Universal
680-19	Thermal Transfer Foil - One Step - Select Seal

Refer to pages 68-69



Select Seal Cards

Item No.	Description
300-13	30-Day
300-14	31-Day
300-15	32-Day
300-32	7-Day/14-Day 9"x6"
300-33	7-Day/14-Day 9"x3"
302-51	On Demand 30-Day Supply

Refer to pages 13-17



Unit Dose Boxes

Item No.	Description
UD-250	(5" x 1 5/8" x 2 1/4")
UD-251	(4 11/16" x 1 9/16" x 2 3/8")



Reorder Alert

Item No.	Description
UD-286	Reorder Alert

MTS Unit Dose Foil Labeling System



This unit dose foil labeling system meets the unique needs of the long-term care pharmacy by producing high quality bar code scannable label sheets quickly and efficiently. It is the only foil printing system developed specifically for pharmacy operations and produces up to 18 sheets per minute.

The Windows-based software is reliable and easy-to-use. You simply scan the medication's NDC bar code and the system prompts you to enter the lot number and expiration date. Additional data entry is also possible, including alternate drug names and customized fields. Changing to 1/2 tabs and 1/4 tabs, for example, is a simple process with "hot-key" field editing. The software also enables you to view the labels before you print.

The printable production report simplifies the process of tracking your pharmacy's daily packaging activity.

OPTION 1 - THERMAL PRINTER

The system includes:

- Tharo H626 - 203dpi Thermal transfer printer
- H626 rotary cutter
- Labeling software program with database and report generator
- Bar code scanner with cable and stand
- Printhead cleaning kit
- Communication cable
- Initial set-up and training

Customer Furnished:

Computer – Windows XP or Vista
Report printer

Usage:

This high-speed durable printer prints up to 18 sheets of MTS foil (576 unit doses) per minute. It is used for packaging efficiency or when bar code printing is required. It automatically cuts the foil to size, ready for direct application to the unit dose blister. The printer can be used as a standalone system or in conjunction with MTS automation.



OPTION 2 - DOT MATRIX PRINTER

Included from MTS:

Unit Dose software
Drug database
Bar code scanner

Customer Furnished:

Computer – Windows XP or Vista
A suitable dot matrix printer *
*Printers are available through MTS

Usage:

This is appropriate for smaller volume packaging when the printing of the NDC bar code is not required on the foil.



OPTION 3 - SOFTWARE ONLY

Included from MTS:

MTS Unit Dose software
Drug database